

9500E

(12 VDC) Power Case/Cassette Awning

Model 231(LL)(CC).003(#)

Introduction	2
Important Safety Instructions and Document Symbols	2
General Information	3
Specifications	3
A. Product Rating	3
B. Door Clearance	3
C. Awning Dimensions	3
Installation	4
A. Installing The Mounting Brackets	4
B. Installing The Wiring And Electrical Kits	6
C. Installing The Awning	7
D. Testing The Motor And Remote Functionality	8
E. Testing The Wind Sensor Functionality (If Equipped)	9
Adjustments (Optional)	9
A. Adjusting The Fabric Slope	9
B. Adjusting The Lateral Arm Assemblies	10
C. Adjusting The Lead Rail Alignment	11
D. Adjusting The Awning Open/Close Limits	11



Read these instructions carefully. These instructions MUST stay with this product.

REVISION E

Form No. 3316981.000 3/19
(French 3316983.000_E)
©2019 Dometic Corporation
LaGrange, IN 46761

USA & CANADA

SERVICE OFFICE
Dometic Corporation
1120 North Main Street
Elkhart, IN 46514

**SERVICE CENTER &
DEALER LOCATIONS**

Visit:
www.Dometic.com

INTRODUCTION

This case awning (hereinafter referred to as “awning,” or “product”) is designed and intended for use on a Recreational Vehicle (hereinafter referred to as “RV”) with straight sides. It is especially well-suited for RVs with an over-cab extension where there is not sufficient surface for a bottom mounting bracket. This product can be installed by one person with brief help from additional personnel. Use these instructions to ensure correct installation and function of the product.

Dometic Corporation reserves the right to modify appearances and specifications without notice.

IMPORTANT SAFETY INSTRUCTIONS AND DOCUMENT SYMBOLS

This manual has safety information and instructions to help you eliminate or reduce the risk of accidents and injuries.

A. Recognize Safety Information



This is the safety alert symbol. It is used to alert you to potential physical injury hazards. Obey all safety messages that follow this symbol to avoid possible injury or death.

B. Understand Signal Words

A signal word will identify safety messages and property damage messages, and will indicate the degree or level of hazard seriousness.

WARNING indicates a hazardous situation that, if **NOT** avoided, could result in death or serious injury.

CAUTION indicates a hazardous situation that, if **NOT** avoided, could result in minor or moderate injury.

NOTICE is used to address practices **NOT** related to physical injury.

i Indicates additional information that is not related to physical injury.

C. Supplemental Directives



Read and follow all safety information and instructions to avoid possible injury or death. Read and understand these instructions before installation of this product.

Incorrect installation of this product can lead to serious injury.

The installation **MUST** comply with all applicable local or national codes, including the latest edition of the following standards:

U.S.A.

- ANSI/NFPA70, National Electrical Code (NEC)
- ANSI/NFPA 1192, Recreational Vehicles Code

CANADA

- CSA C22.1, Parts I & II, Canadian Electrical Code
- CSA Z240 RV Series, Recreational Vehicles

D. General Safety Messages

WARNING Failure to obey the following warnings could result in death or serious injury:

- This product **MUST** be installed by a qualified service technician.
- Do **NOT** modify this product in any way. Modification can be extremely hazardous.

NOTICE This product is for use with 12 VDC only.

GENERAL INFORMATION

REQUIRED TOOLS

Drill (optional)	6 mm Hex Key/Driver/Bit
Torque Wrench	6 mm Hex Key Socket
Phillips Screwdriver/Bit	10 mm Socket
3 mm Hex Key/Driver/Bit	

REQUIRED HARDWARE (8'-16' MODELS)

(1) Mounting Bracket	(12) M6 Flat Washer
(12) M6 x 50 mm L Carriage Bolt	(12) M6 Locknut With Nylon Insert
(12) M6 Split Lock Washer	(6) #8-18 x 0.38 Self-Drilling Flat-Head Screw

ADDITIONAL REQUIRED HARDWARE FOR 15'-16' MODELS ONLY

(4) M6 x 50mm L Carriage Bolt	(4) M6 Locknut With Nylon Insert
(4) M6 Split Lock Washer	(2) #8-18 x 0.38 Self-Drilling Flat-Head Screw
(4) M6 Flat Washer	

SPECIFICATIONS

A. Product Rating

	VOLTAGE	CURRENT	SPEED	PROTECTION INDEX
POWER SUPPLY	12 VDC	5 A	N/A	N/A
MOTOR RATING	12 VDC	3.7 A	15 RPM	IP44

- **Duty Cycle:** Intermittent, three minutes (2 cycles; extend and retract)

i To prevent overheating, after three minutes of constant operation, the awning motor briefly halts operation to cool.

B. Door Clearance

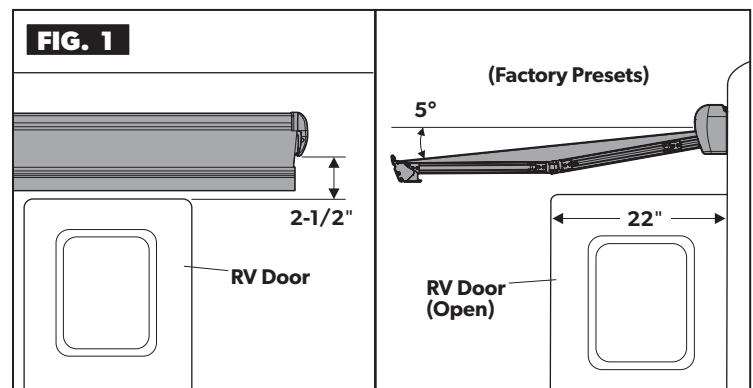

NOTICE Allow for sufficient clearance between awning fabric and entry door to accommodate awning pitch (slope).

i Awning fabric adjusts up to a 15° slope.

C. Awning Dimensions

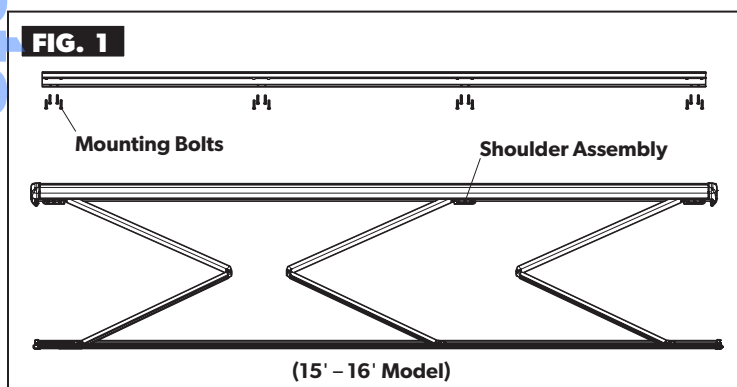

⚠ WARNING IMPACT OR CRUSH HAZARD. Locate mounting bolts behind each shoulder assembly (lateral arm attachment) to provide proper support. Otherwise, awning may become unstable and could bend or collapse. Failure to obey this warning could result in death or serious injury.

SPECIFICATIONS

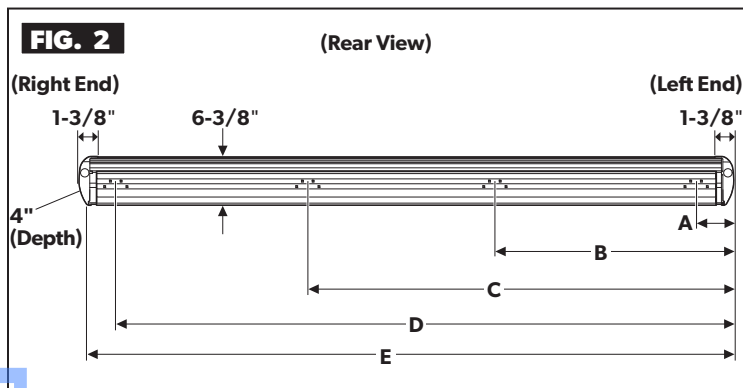

HOLE PATTERN LOCATIONS						
	8'	10'	12'	13'	15'	16'
A	6-3/8"					
B	N/A				60-7/8"	
C	50-5/8"	60-7/8"	69-1/4"	79"	116-3/8"	
D	94-3/4"	115-1/4"	132"	151-5/8"	180-1/4"	191"
E	101-1/8"	121-5/8"	138-3/8"	158"	186-5/8"	197-3/8"

INSTALLATION

⚠ WARNING IMPACT OR CRUSH HAZARD. Make sure mounting surface on RV is flat, has solid structural backing where fasteners penetrate surface, and will safely and securely support product. Otherwise, product may become unstable and could detach, bend, or collapse. Failure to obey this warning could result in death or serious injury.

(i) Make sure the mounting surface on the RV is flat and vertical. Any tilt affects the awning pitch (slope) and door clearance. Maintain a minimum of 1/2" clearance at the top and sides of the awning case for service access.

A. Installing The Mounting Brackets

⚠ WARNING Failure to obey these warnings could result in death or serious injury:

- **FIRE OR ELECTRICAL SHOCK HAZARD.** Make sure there are no obstacles (wires, pipes, etc.) inside RV's walls, roof, or floor. Shut OFF gas supply, disconnect 120 VAC power from RV, and disconnect positive (+) 12 VDC terminal from supply battery **BEFORE** drilling or cutting into RV.
- **IMPACT OR CRUSH HAZARD.** Do **NOT** over tighten fasteners. Applying too much torque may cause fasteners or threads to fail, and could allow product to collapse.

NOTICE **ALWAYS** use sealant on (clean) parts and surfaces where fasteners enter RV's walls, roof, or floor. Otherwise, water leakage could occur.

- Disconnect power to the RV.
- Determine the installation location for the awning mounting brackets.

INSTALLATION

Mounting To A Solid Structure

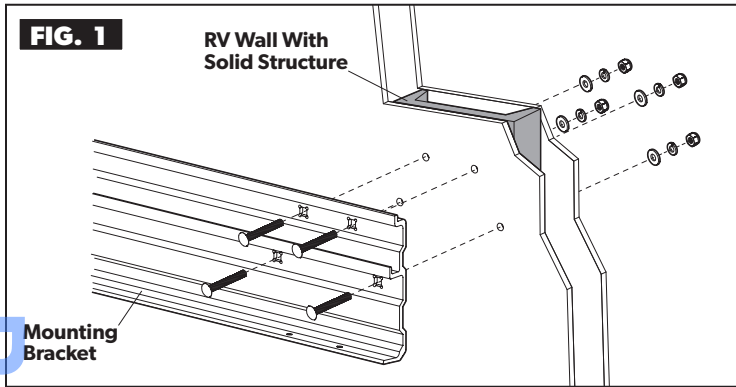

- i** A solid structure reaches from the RV floor to the roof and matches the width of the mounting bolt pattern behind each shoulder assembly.

Mounting To A Non-Solid Structure

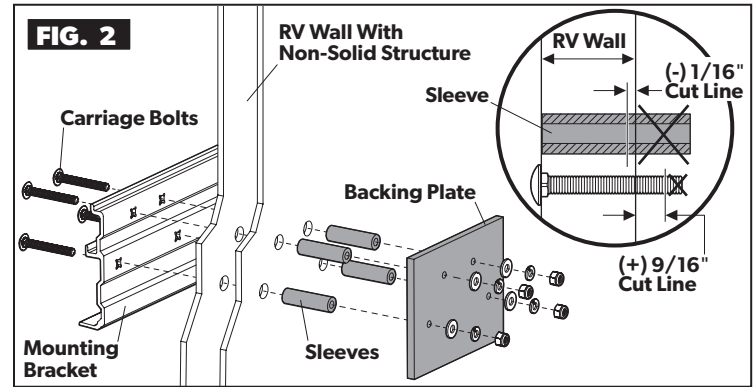

- i** A non-solid structure requires the use of a backing plate on the inside RV wall in conjunction with sleeves and carriage bolts to support the awning. RV wall thicknesses over 1-7/16" require bolts longer than the provided M6 bolts, with a bolt head no taller than 1/8".
 - Sleeves and carriage bolts (Grade 8.8 minimum) **MUST** be cut to fit the RV wall, then repaired (where cut) **PRIOR** to installation.

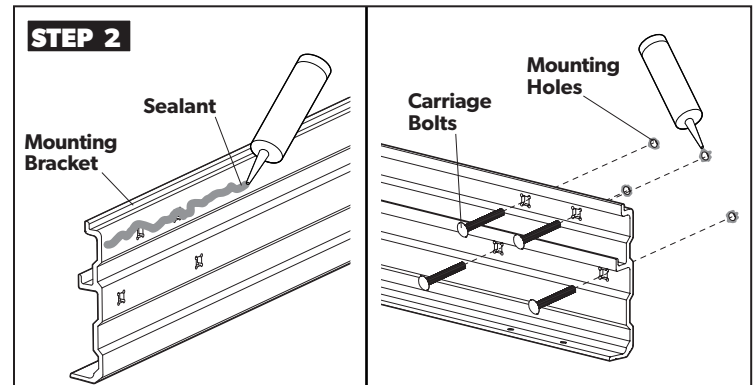
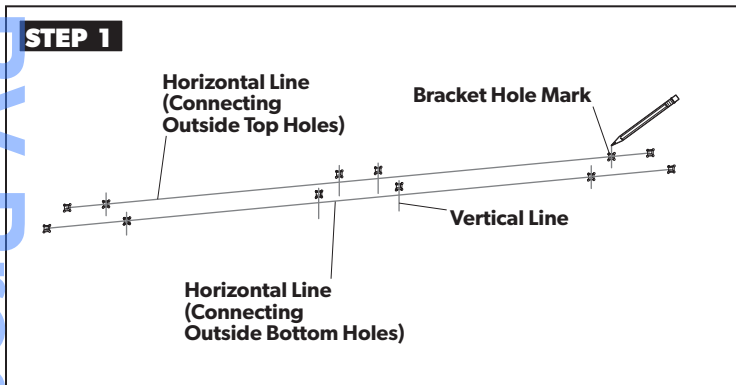

- Place the mounting bracket in the appropriate installation location and, using a pencil, mark the bracket holes.
- Making sure each line is horizontal, draw two lines: one connecting the two outside top holes, and one connecting the two outside bottom holes.
- i** Due to the nature of long extruded parts, the mounting bracket may be slightly bowed. Some hole locations may be above or below marked horizontal lines.
- Draw vertical lines from each remaining hole to the closest horizontal line and mark the intersection point for drilling.
- Drill clearance holes at each intersecting points on the horizontal lines.
 - For a solid structure mount: drill 1/4" clearance holes.
 - For a non-solid structure mount: if sleeves are used, larger clearance holes are necessary. Drill appropriately sized clearance holes to accommodate the sleeves.

- Apply sealant to the edge of the mounting bracket and around the drilled holes.
- Secure the mounting bracket to the RV wall.
 - For a solid structure mount, see "Mounting To A Solid Structure" on page 5.
 - For a non-solid structure mount, see "Mounting To A Non-Solid Structure" on page 5.
- Torque carriage bolts to 35 ±5 in-lb.

INSTALLATION

B. Installing The Wiring And Electrical Kits

⚠ WARNING Failure to obey the following warnings could result in death or serious injury:

- ELECTRICAL SHOCK HAZARD. Disconnect 120 VAC power from RV.
- IMPACT OR CRUSH HAZARD. Do **NOT** install product without also installing an ignition/safety interlock system. Otherwise, accidental operation during transit could occur.
- FIRE OR ELECTRICAL SHOCK HAZARD. Make sure there are no obstacles (wires, pipes, etc.) inside RV's walls, roof, or floor. Shut OFF gas supply, disconnect 120 VAC power from RV, and disconnect positive (+) 12 VDC terminal from supply battery **BEFORE** drilling or cutting into RV.

NOTICE Failure to obey the following notices could damage product or property:

- Disconnect the positive (+) 12 VDC terminal from supply battery. Otherwise, damage to unit could occur.
- Do **NOT** pinch wiring or allow wiring to rub against sharp edges. If wiring is damaged, it **MUST** be replaced by a qualified service technician.
- **ALWAYS** seal wiring against weather and moisture where wiring enters RV's walls, roof, or floor. Otherwise, water leakage could occur.

i Wire colors noted within this section are industry standard. Some RV manufacturers use different colors. Refer to RV wiring schematics for more detail. Use the appropriate wire gauge for each wire run.

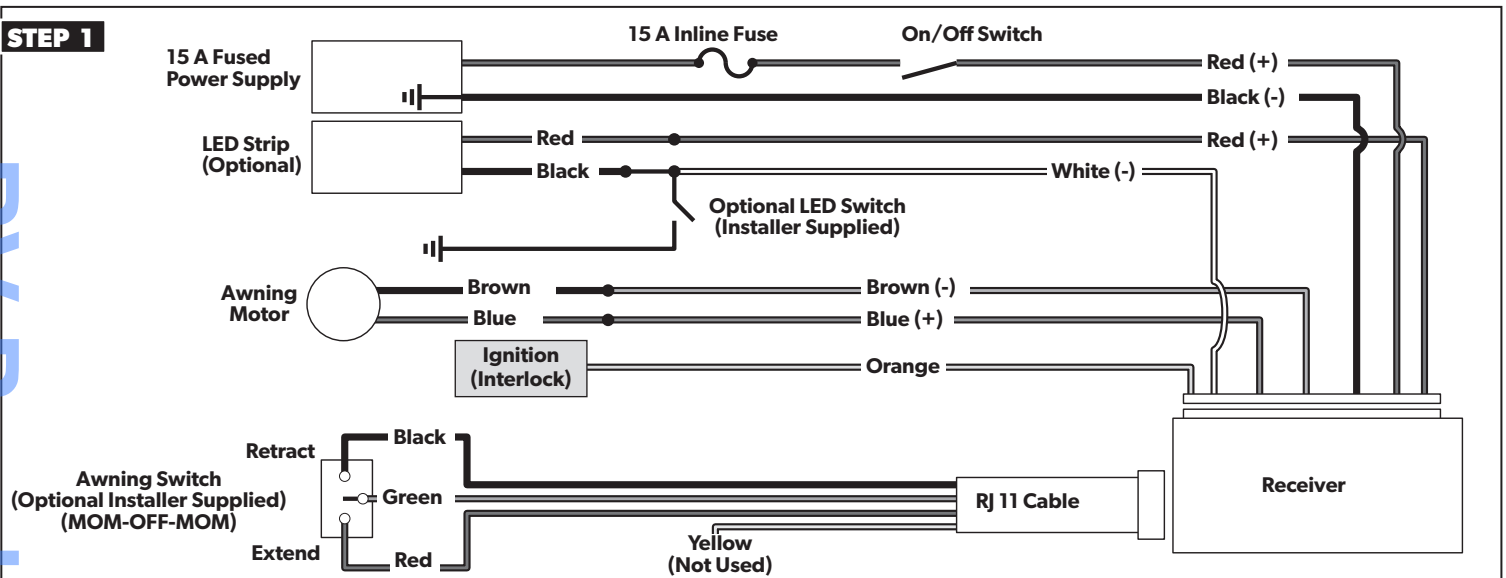

- Inside the RV, route one BLACK wire and one RED wire from the 12 VDC power supply to the receiver location and connect.
- If applicable, install the wiring for the ignition/safety interlock. Connect the (+) 12 VDC ignition terminal to the ORANGE receiver wire.
- Wire the receiver to the awning motor. Connect one BLUE wire and one BROWN wire from the location of the receiver to the awning motor location. Use a wiring length long enough to pass through the outside RV wall for connection to the awning.
- If applicable, wire the receiver to the LED lights. Connect one WHITE wire and one RED wire from the location of the receiver to the LED light location. Use a wiring length long enough to pass through the outside RV wall for connection to the LED lights.

INSTALLATION

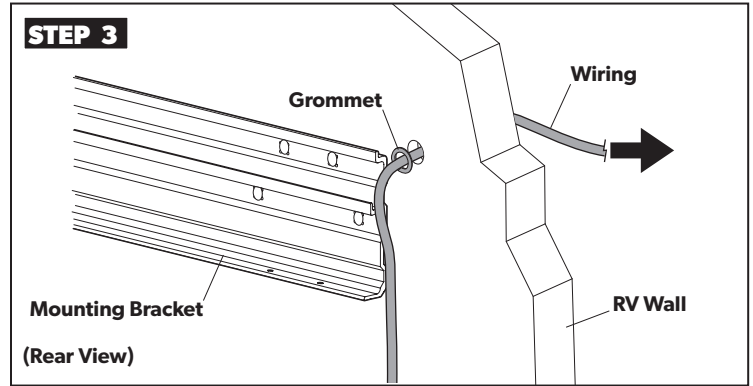
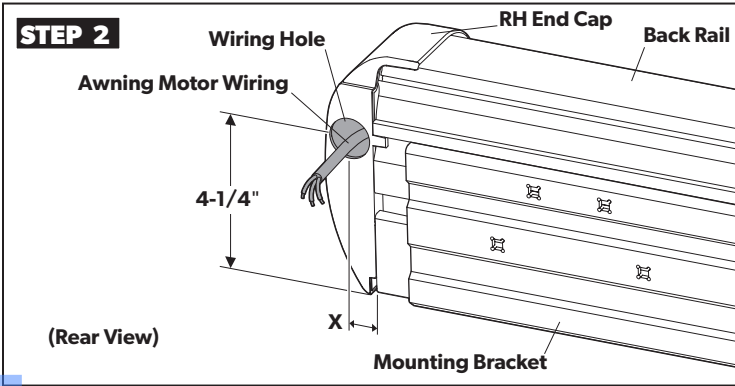

i The distance from the end of the bracket to the end of the back rail may not be constant.

- Calculate the awning wiring hole location:

Horizontal distance calculation (X):

$$X = [(\text{awning back rail length} - \text{awning bracket length}) / 2] + 5/8"$$

Vertical distance measurement:

1. Measure out the horizontal distance from the RH edge of the installed awning bracket, then draw a vertical line.
2. Measure up 4-1/4" from the bottom of the bracket and place a horizontal line intersecting the vertical line just drawn. This is the wiring hole location.

- Drill a 5/8" hole at the intersection of the horizontal and vertical lines.
- Route wires through the RV wall, using a grommet (installer-supplied) or heat-shrink tubing (installer-supplied).
- Connect the RV wiring to the awning motor wiring, using a connector.

C. Installing The Awning

⚠ WARNING Failure to obey the following warnings could result in death or serious injury:

- **IMPACT OR CRUSH HAZARD.** Do **NOT** extend awning until it is securely hooked and mounted onto mounting bracket(s). Take special care when extending. Otherwise, awning could dislodge and fall.
- **IMPACT OR CRUSH HAZARD.** Do **NOT** operate or leave awning unattended until it is securely fastened to mounting bracket(s). Otherwise, awning could dislodge and fall.

⚠ CAUTION **LIFTING HAZARD.** Use proper lifting technique and control when lifting product. Failure to obey this caution could result in injury.

NOTICE Failure to obey the following notices could damage product or property:

- Do **NOT** pinch wiring or allow wiring to rub against sharp edges. If wiring is damaged, it **MUST** be replaced by a qualified service technician.
- Do **NOT** expose remote and remote holster to weather, extreme temperatures, or long hours in direct sunlight.

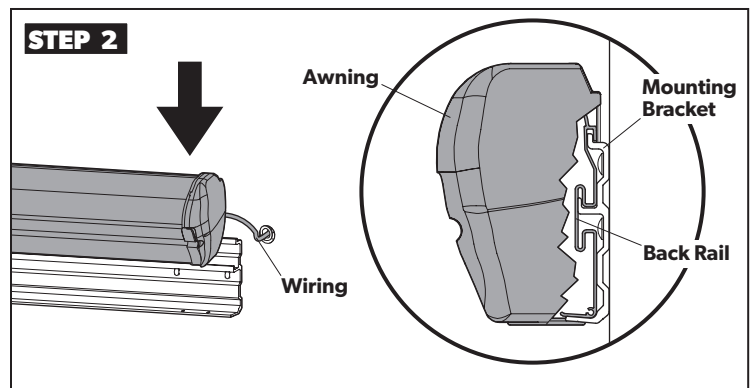
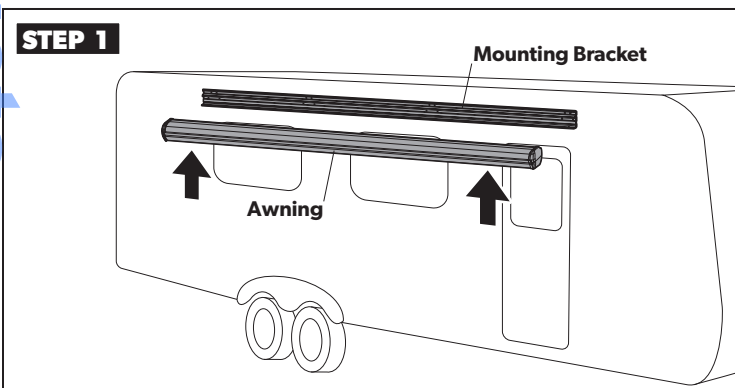

- With additional help, lift the awning up to the mounting bracket and connect the wiring.

- Hook the awning to the mounting brackets.
- i** Before securing the awning, confirm the wiring connections are complete and wires are not caught between the awning and the RV wall.

Panther RV Products

INSTALLATION

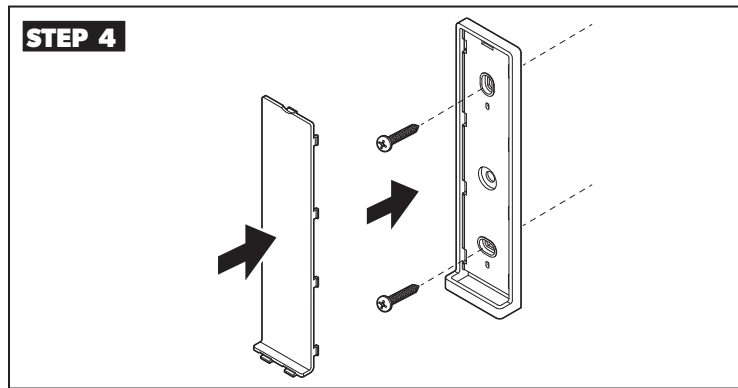
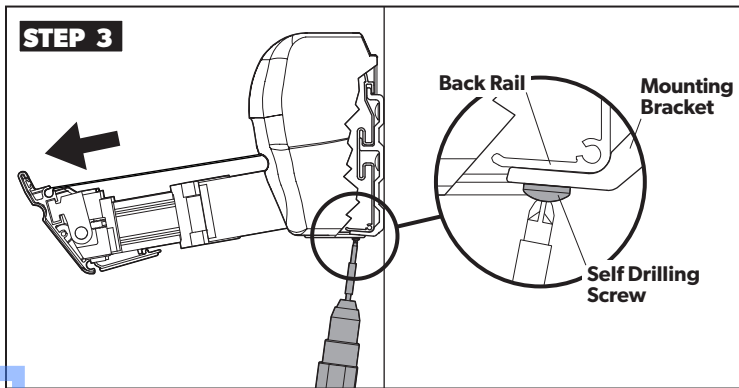

- Turn on the power to the RV and extend the awning 1' to verify the back rail is contacting the mounting bracket.
- Turn off the power to the RV, then secure the awning to the mounting bracket using the self-drilling screws.

- Install the remote holster in a protected area using two screws.

D. Testing The Motor And Remote Functionality

CAUTION PINCH HAZARD. Maintain a horizontal distance of at least 16" between fully open awning and any permanent object. Failure to obey this caution could result in injury.

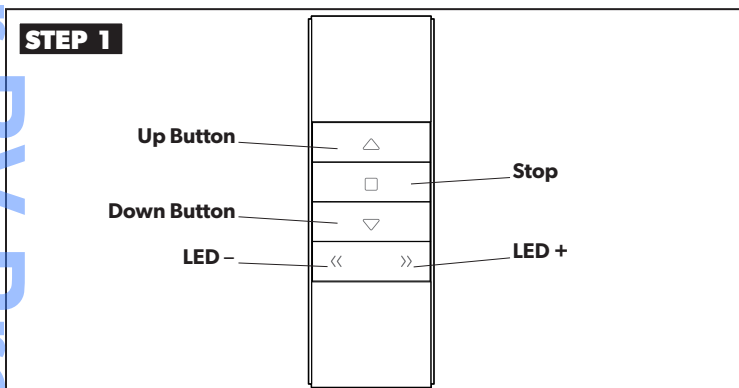

BUTTON	FUNCTION
Up	Retracts the awning (one touch)
Stop	Stops the awning at an intermediate position
Down	Extends the awning (one touch)
LED -	Dims the LED light(s)
LED +	Brightens the LED light(s)

- Turn on the power to the RV and press the awning remote buttons to confirm correct function.

i If the awning does **NOT** perform as indicated, refer to the troubleshooting guide in the operating instructions.

INSTALLATION

E. Testing The Wind Sensor Functionality (If Equipped)

⚠ CAUTION PINCH HAZARD. Maintain a horizontal distance of at least 16" between fully open awning and any permanent object. Failure to obey this caution could result in injury.

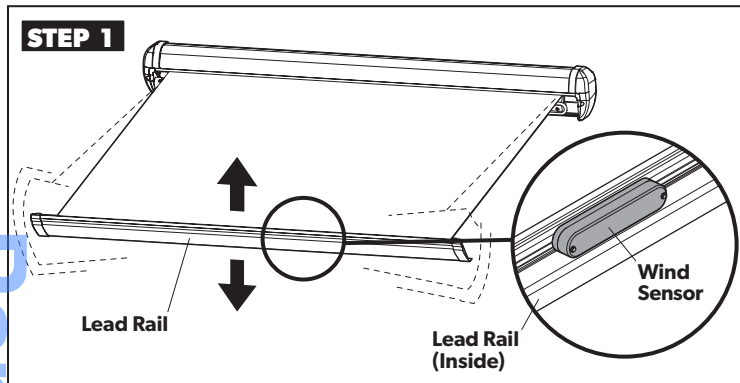

- With the awning fully extended, raise and lower the lead rail 3" to 4" for approximately eight seconds. The awning fully retracts and disables for one minute to prevent re-opening during damaging conditions.

i If the awning does **NOT** perform as indicated, refer to the troubleshooting guide in the operating instructions.

ADJUSTMENTS (OPTIONAL)

A. Adjusting The Fabric Slope

⚠ WARNING IMPACT OR CRUSH HAZARD. Make sure lateral arm assemblies are tied and supported securely (with lead rail) before loosening fasteners. Otherwise, the lead rail and lateral arm assemblies could shift or drop quickly and unexpectedly. Failure to obey this warning could result in death or serious injury.

⚠ CAUTION PINCH HAZARD. Keep CLEAR of pivot area while raising or lowering lateral arm assembly. Failure to obey this caution could result in injury.

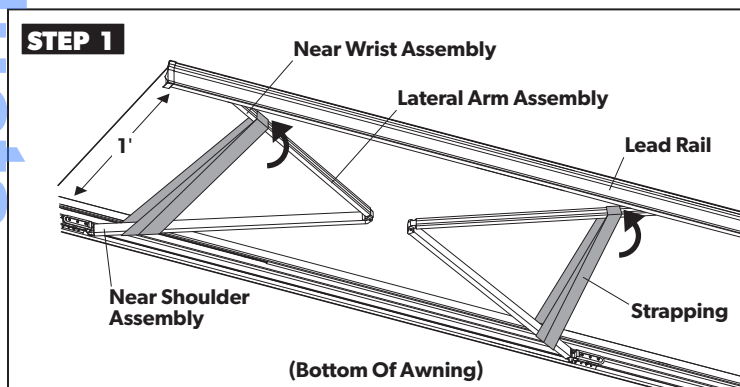

- Extend the awning 1' and tie the lateral arm assemblies near the wrist and shoulder assemblies.
- Support the weight of the lead rail and lateral arm assemblies before making adjustments. Adjust one lateral arm assembly at a time.

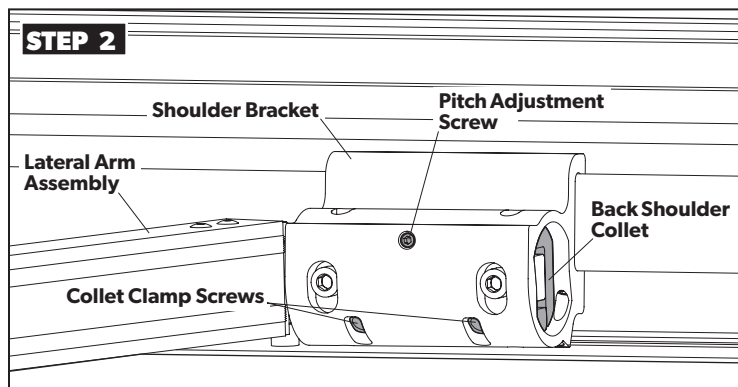

- Carefully loosen the collet clamp screws and the pitch adjustment screw, then lower the lead rail to the desired position.
- Retighten the pitch adjustment screw until resistance is felt.
- Torque the collet clamp screws to 140 in-lb.
- Repeat for each lateral arm assembly.
- Remove all ties and supports, then verify awning operation.

ADJUSTMENTS (OPTIONAL)

B. Adjusting The Lateral Arm Assemblies

⚠ WARNING IMPACT OR CRUSH HAZARD. Make sure lead rail and lateral arm assemblies are supported securely before loosening fasteners. Do **NOT** completely remove fasteners, or loosen them so far that shoulder base will disengage from shoulder bracket. Otherwise, the lead rail and lateral arm assemblies could shift or drop quickly and unexpectedly, or lateral arm assemblies could extend to the side (beyond awning perimeter) quickly and unexpectedly. Failure to obey this warning could result in death or serious injury.

NOTICE Do **NOT** allow lateral arm assemblies to rub against lower lip of back rail when closing, or allow awning fabric to contact shoulder base when fully opened. Otherwise, premature wear and abrasions could occur.

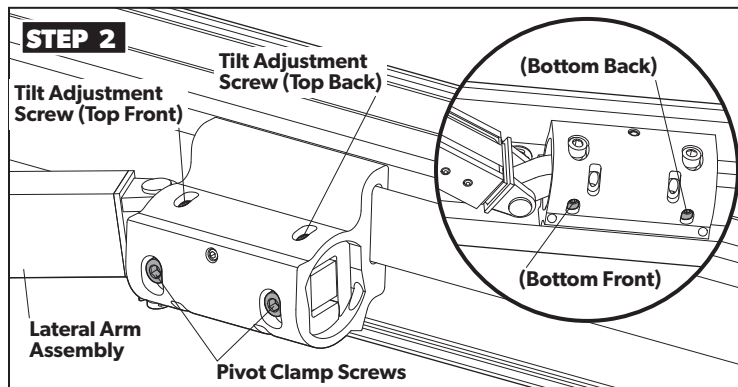
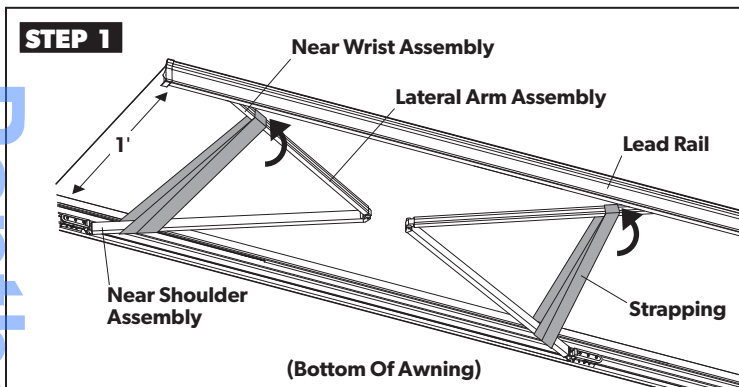

- Extend the awning 1' and tie the lateral arm assemblies near the wrist and shoulder assemblies.
- Support the weight of the lead rail and lateral arm assemblies before making adjustments. Adjust one lateral arm assembly at a time.

- Slightly loosen the pivot clamp screws for each lateral arm assembly requiring adjustment.

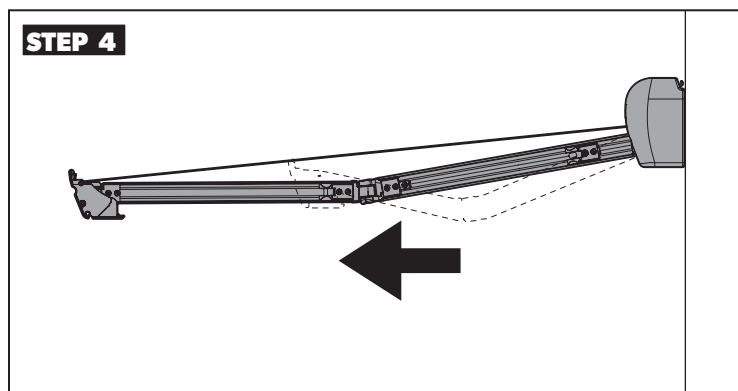
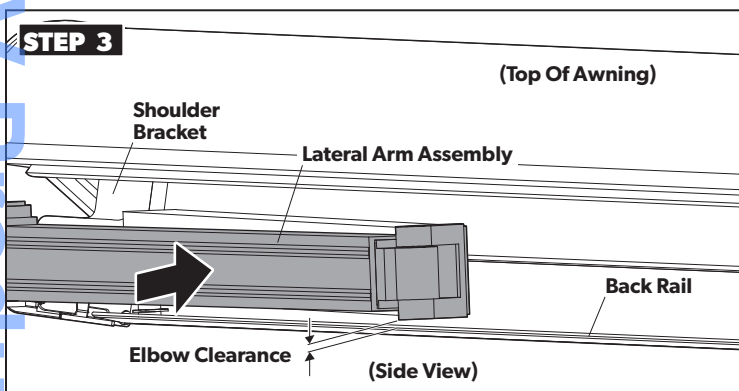

- Retract the awning until the lateral arm assembly elbow meets the top and back rail. Adjust one lateral arm assembly at a time.
- To increase (raise) elbow clearance:
 1. Loosen the top-front and the bottom-back tilt adjustment screws.
 2. Adjust the lateral arm assembly closing height, as needed.
 3. Retighten the tilt adjustment screws.
 4. Repeat steps as necessary for desired clearance.
- To decrease (lower) elbow clearance:
 1. Loosen the top-back and the bottom-front tilt adjustment screws.
 2. Adjust the lateral arm assembly closing height, as needed.
 3. Retighten the tilt adjustment screws.
 4. Repeat steps as necessary for desired clearance.

- Extend the awning approximately 1'.
- Torque the pivot clamp screws to 140 in-lb.
- Repeat for each lateral arm assembly.
- Remove all ties and supports, then verify awning operation.

ADJUSTMENTS (OPTIONAL)

C. Adjusting The Lead Rail Alignment

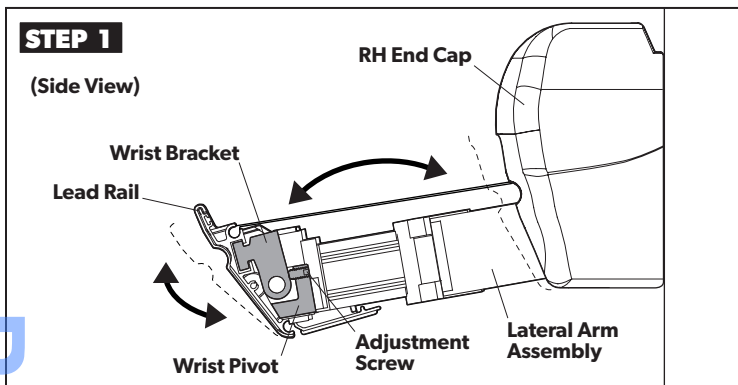

- Extend the awning approximately 6".
- Turn the adjustment screw on each lateral arm assembly:
 - Turn clockwise to tilt the lead rail forward.
 - Turn counter-clockwise to tilt the lead rail backward.
- Retract the awning and check the lead rail alignment with the top and end caps.
- Repeat steps as necessary.

D. Adjusting The Awning Open/Close Limits

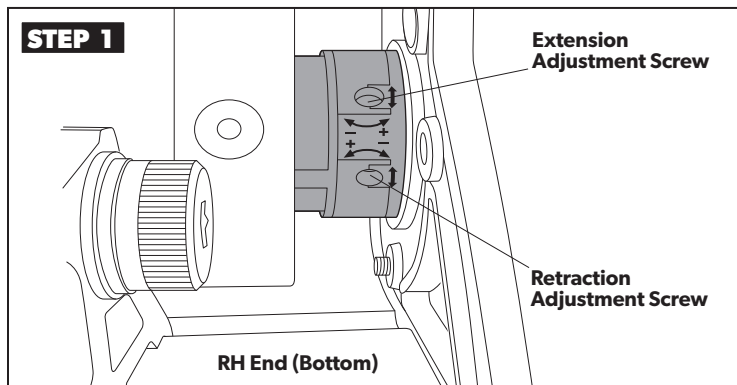

- **i** The motor should turn off and stop turning when the awning is fully closed. If the motor continues turning after the awning closes, damage to the motor or awning components may occur.
- To adjust the awning so the front rail fits tightly against the case when the awning is fully closed:
 - Turn the retraction adjustment screw clockwise for less awning retraction.
 - Turn the retraction adjustment screw counterclockwise for more awning retraction.
- To adjust the awning so the fabric is not under extended or sagging when the awning is fully open:
 - Turn the extension adjustment screw clockwise for less awning extension.
 - Turn the extension adjustment screw counterclockwise for more awning extension.